

# Multilane Stickpack Machine **ST1200**



By adding the ST1200 to our portfolio, Viking Masek continues to lead the stickpack machine market with an outstanding range of machines. The ST1200 is the newest high-performance stickpack machine using state-of-the-art technology.

max. speed  
**80**  
cpm

bag size  
max. 100 × 200 mm (3.94" × 7.88")  
min. 17 × 40 mm (0.67" × 1.57")



Bag Types

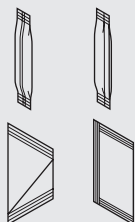

Bag Options

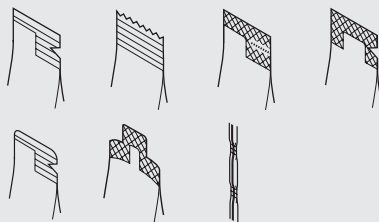

# Multilane Stickpack Machine ST1200 In Detail

Designed to pack powders; dense, fine, loose and particulate materials as well as liquids and gels into stickpack bags and to accommodate different bag shapes including pour spouts, tear notches and easy-open systems. We also offer fully automated cartoning solutions to suit your needs.

## features



- Powered film unwind with film tension control
- Film slitters and forming tubes – set per bag size
- Discharge chutes
- Siemens or Allen Bradley control system
- Automatic film tracking
- GMP construction
- Easy change-over™
- Quick film splice table
- Photo eye for bag length control

## options



- Straight cut
- Zigzag cut
- Round cut
- Die cut
- Easy change-over parts and stainless steel storage cart
- Easy open features like tear notch, microperforation or laser score
- Various seal patterns and shapes
- Offset back seal
- Automatic stickpack length adjustment
- Individual discharge chutes
- Empty stick detection
- Empty stick rejection
- Dust suction nozzles
- Static elimination
- Film edge trimming and suction
- Embossing in the longitudinal seal
- Stainless steel construction
- Pharma construction (IQ/OQ)
- Hot stamp, Inkjet, or thermal transfer printer
- Multi-lane volumetric filler, servo auger filler or servo liquid fillers
- Robotic pick-and-place unit and automatic cartoning solutions
- In-feed and out-feed conveyors

## Max. speed

80 cpm

## Weight

1 600 kg (3,525 lbs)

## Bag width

17–100 mm  
(0.67”–3.94”)

## Air pressure

6 bar  
(15 CFM at 90 PSI)

## Bag length

40–200 mm  
(1.57”–7.88”)

## Power supply

10 kVA

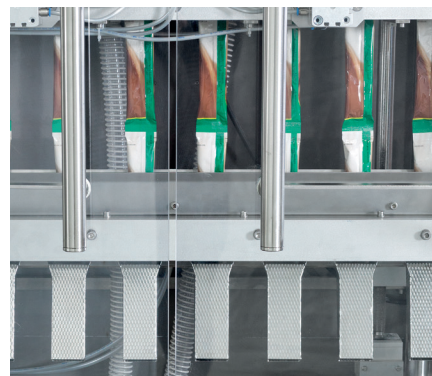

## Machine drawings

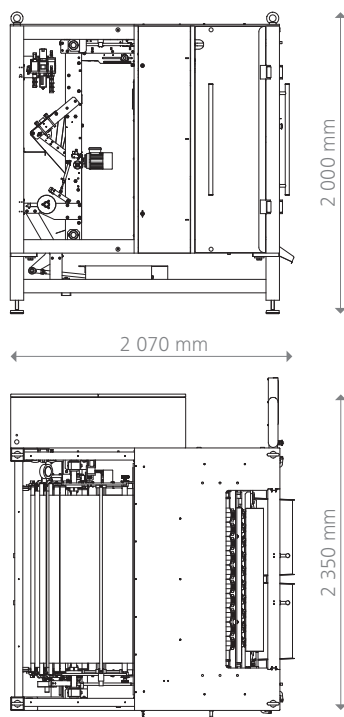

### Europe, Asia, Africa, Australia

Viking Mašek, a.s. | Průmyslová 1747 | 258 01 Vlašim | Czech Republic

Phone +420 317 850 500 | Email [info@masek.cz](mailto:info@masek.cz) | Website [www.masek.cz](http://www.masek.cz), [www.vikingmasek.cz](http://www.vikingmasek.cz)

### North and South America

Viking Masek Global Packaging Technologies, Inc. | 40 Woodland Court | Oostburg, WI 53070 | USA

Phone +1 920 564 5051 | Email [sales@vikingmasek.com](mailto:sales@vikingmasek.com) | Website [www.vikingmasek.com](http://www.vikingmasek.com)