

# Intermittent Bagmaker S250/300



Our rugged S250/300 vertical bagger delivers exceptional speed and repeatability through a quiet, servo driven jaw. This vertical bagmaker is perfect for packaging snacks, candy, coffee, fresh and frozen fruit, and more.

max. speed

150  
bpm

bag size

max.  
250 × 400 mm (9.84" × 15.75")  
300 × 400 mm (11.81" × 15.75")  
min.  
50 × 60 mm (1.96" × 2.38")



Bag Types

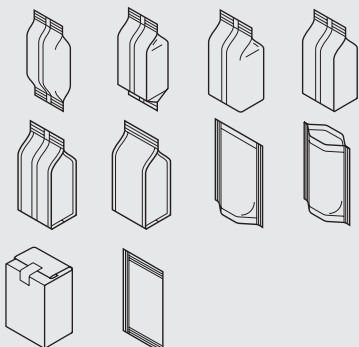

Bag Options

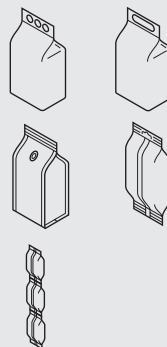

Recloseable Solutions

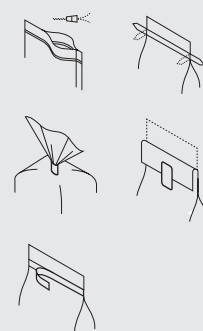

# Intermittent Bagmaker S250/300 In Detail

What's better than a highly reliable bagger with a repeatable delivery? One that's also incredibly fast. Meet the S250/300, an impressive vertical form, fill and seal machine that provides the stainless steel sanitary design and affordability you've come to expect from our S Series. Want efficiency? With speeds up to 150 bags per minute, faster, repeatable and accurate production runs will be the norm. Want consistency? The S250/300 prevents bottlenecks. Want flexibility? The S250/300 accommodates several bag styles, including quad-seal. Want peace of mind? Make the S250/300 your next investment.

## features



- Robust, stainless steel frame
- Siemens or Allen Bradley control system
- Servo-drive jaw actuation
- Open frame design
- Off-the-shelf components
- Minimal maintenance requirements
- Short film path
- Small machine footprint
- No tool changeover
- Self-centering pull belts
- Automatic film tracking
- VFD powered film unwind
- Quick film splice table
- Photo eye and encoder
- Automatic machine stop
- Jaw obstruction detection
- Runs most film structures
- Storage for 100 product recipes

## Machine drawings

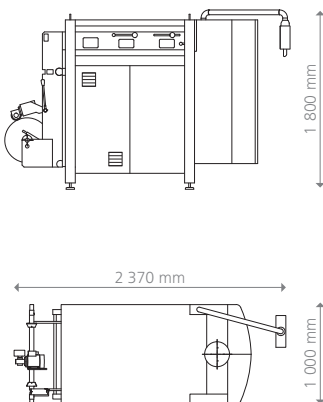

## options



- Upgrade 300 mm bag width
- Continuous motion mode
- Ultrasonic sealing jaws
- Quad seal bag assembly
- Servo pull belts actuation
- Flat bottom bag assembly
- Impulse sealing for poly film structures
- Washdown IP66 construction
- Vacuum pull belts
- Fold-down/tape-down unit
- Hole punch (Euroslot and Round)
- Load shelf
- Product settler
- Gas flush
- Static elimination
- Tear notch
- Product stagers
- End-seal cooling air
- Bag deflators
- Degassing valve applicator
- Remote diagnostics
- Zipper applicator
- Bag-in-bag configuration
- Integration with variety of fillers, printers, metal detectors, label applicators, and checkweighers
- In-feed and take-away conveyors

## Max. speed

150 bpm

## Weight

950 kg (2,095 lbs)

## Bag width

50–250/300 mm  
(1.96"–9.84"/11.81")

## Air pressure

6 bar  
(15–18 CFM at 90 PSI)

## Bag length

60–400 mm  
(2.38"–15.75")

## Power supply

7.9 kVA



### Europe, Asia, Africa, Australia

Viking Mašek, a.s. | Průmyslová 1747 | 258 01 Vlašim | Czech Republic

Phone +420 317 850 500 | Email [info@masek.cz](mailto:info@masek.cz) | Website [www.masek.cz](http://www.masek.cz), [www.vikingmasek.cz](http://www.vikingmasek.cz)

### North and South America

Viking Masek Global Packaging Technologies, Inc. | 40 Woodland Court | Oostburg, WI 53070 | USA

Phone +1 920 564 5051 | Email [sales@vikingmasek.com](mailto:sales@vikingmasek.com) | Website [www.vikingmasek.com](http://www.vikingmasek.com)