

Multilane Stickpack Machine ST400

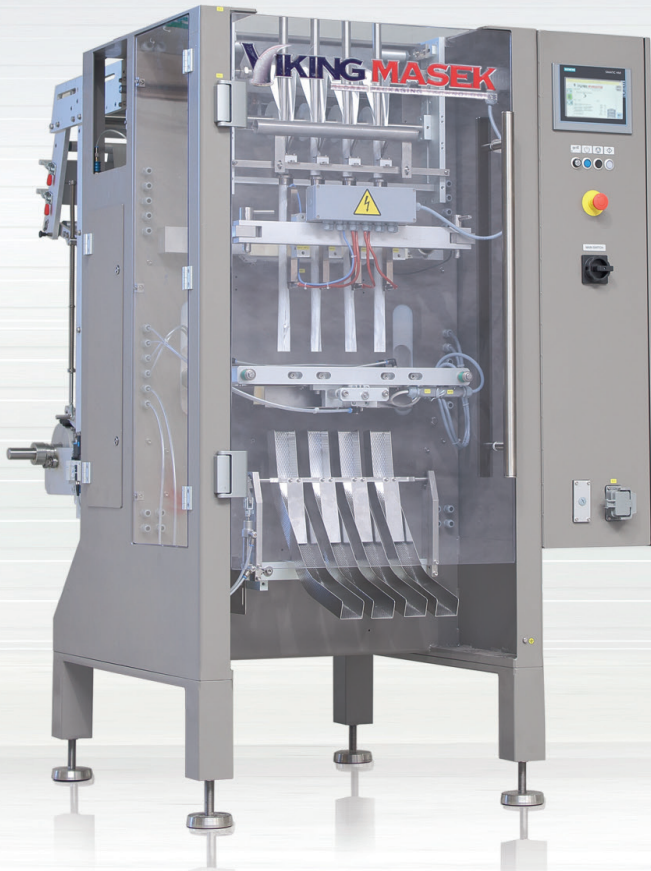

Our ST400 machines are economical stickpack solutions, maintaining all the advantages of their larger brothers. ST400 machines offer you flexibility, versatility, performance, ruggedness, high quality and reliability, and first class service.

max. speed

65
cpm

bag size

max.
40 × 200 mm (1.57" × 7.88")
min.
17 × 40 mm (0.67" × 1.57")



Bag Types

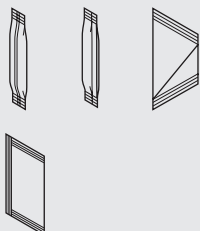

Bag Options

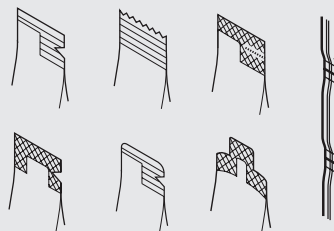

Multilane Stickpack Machine ST400 In Detail

Looking for an economical solution for your stickpack needs? Our versatile multilane ST400 stickpack can accommodate from 1 to 10 lanes to form different shapes of stickpack pouches. Designed to pack powders; dense, fine, loose and particulate materials as well as liquids into stickpack bags and to accommodate different bag shapes including pour spouts, tear notches and easy-open system. Semi- or fully automated cartoning solutions are also available for individual or bulk cartoning.

Max. speed
65 cpm

Weight
600 kg (1,325 lbs)

Bag width
17–40 mm
(0.67"–1.57")

Air pressure
6 bar
(15 CFM at 90 PSI)

Bag length
40–200 mm
(1.57"–7.88")

Power supply
6 kVA

features



- Film unwind with film tension control
- Film slitters and forming tubes – set per bag size
- Discharge chutes
- Siemens or Allen Bradley control system
- Automatic film tracking
- Integrated inner light
- Easy change-over™

options



- Straight cut
- Zigzag cut
- Round cut
- Multi-lane volumetric filler, servo auger filler or servo liquid fillers
- Easy change-over parts and stainless storage cart
- Easy open features like tear notch or microperforation
- Various seal patterns and shapes
- Offset back seal
- Automatic stickpack length adjustment
- Individual discharge chutes
- Empty stick detection
- Empty stick rejection
- Dust suction nozzles
- Static elimination
- Film edge trimming and suction
- Embossing in the longitudinal seal
- Stainless steel construction
- Pharma construction (IQ/OQ)
- Robotic pick-and-place unit and automatic cartoning solutions
- Hot stamp, Inkjet, or thermal transfer printer
- In-feed and out-feed conveyors

Machine drawings

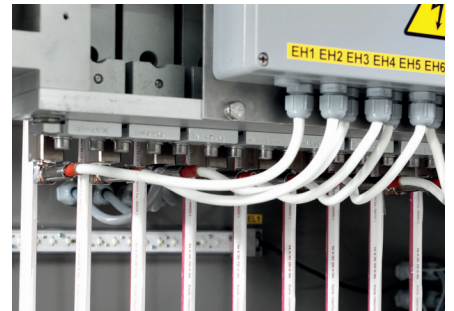
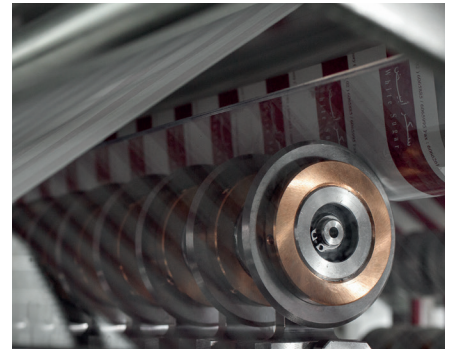
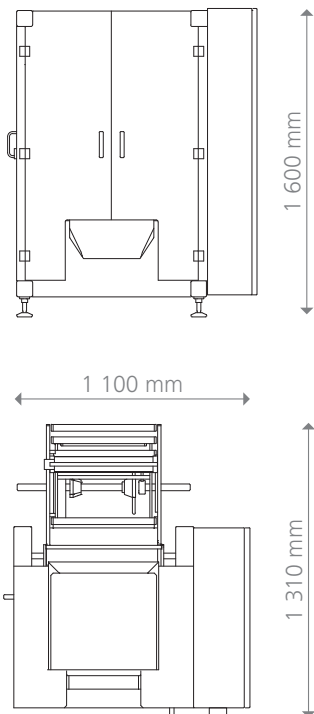

Europe, Asia, Africa, Australia

Viking Mašek, a.s. | Průmyslová 1747 | 258 01 Vlašim | Czech Republic
Phone +420 317 850 500 | Email info@masek.cz | Website www.masek.cz, www.vikingmasek.cz

North and South America

Viking Masek Packaging Technologies, Inc. | 40 Woodland Court | Oostburg, WI 53070 |
USA Phone +1 920 564 5051 | Email sales@vikingmasek.com | Website www.vikingmasek.com