

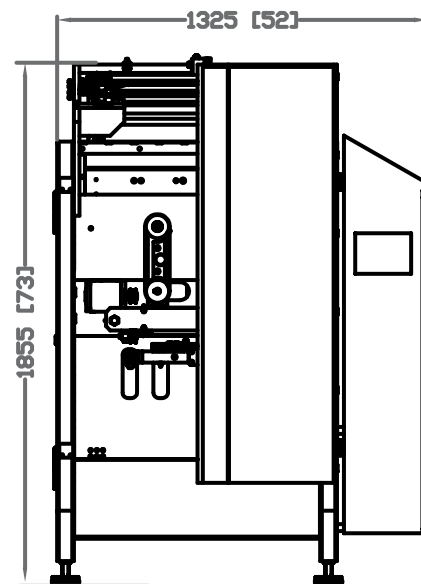

## SPECIFICATIONS

Model	Sigma 250	Sigma 300	Sigma 400
Maximum speed (dry cycle)	Up to 220 cycles/minute	Up to 220 cycles/minute	Up to 200 cycles/minute
Maximum bag size	250mm x 1000mm (9.8" x 39.3")	300mm x 1000mm (11.8" x 39.3")	400mm x 1000mm (15.75" x 39.3")
Minimum bag size	60 mm x 120 mm	60 mm x 120 mm	60 mm x 120mm
Maximum roll diameter	450 mm (17.7")	450 mm (17.7")	450 mm (17.7")
Maximum Roll Width	545 mm (21.4")	645 mm (25.3")	850mm (33.4")
Drive	Linear motion drives and servo motors	Linear motion drives and servo motors	Linear motion drives and servo motors
Machine dimensions w/o filler	1350 mm (53") wide x 2100 mm (83") high x 1950 mm (77") deep	1350 mm (53") wide x 2100 mm (83") high x 1950 mm (77") deep	1600 mm (63") wide x 2300 mm (91") high x 1950 mm (77") deep
Electrical requirements	Standard 480V, three phase, 60Hz.	Standard 480V, three phase, 60Hz.	Standard 480V, three phase, 60Hz.
Air requirements	12-18 SCFM @ 90 PSI	12-18 SCFM @ 90 PSI	12-18 SCFM @ 90 PSI
Control system	Allen Bradley or Siemens controls	Allen Bradley or Siemens controls	Allen Bradley or Siemens controls
Construction	Stainless steel	Stainless steel	Stainless steel

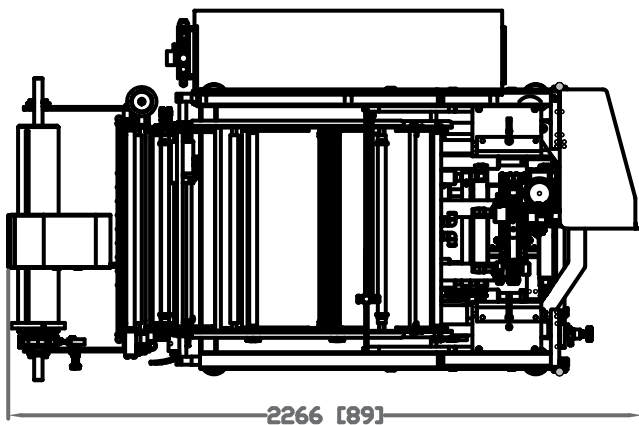

**SIGMA**