

# Multilane Stickpack Machine **ST800**

Viking Masek ST800 stickpack machines offer multilane packaging for a variety of products like powders, granulates or liquids. Our ST800 stickpack machines produce beautiful stickpacks up to 80 mm wide by up to 200 mm long.

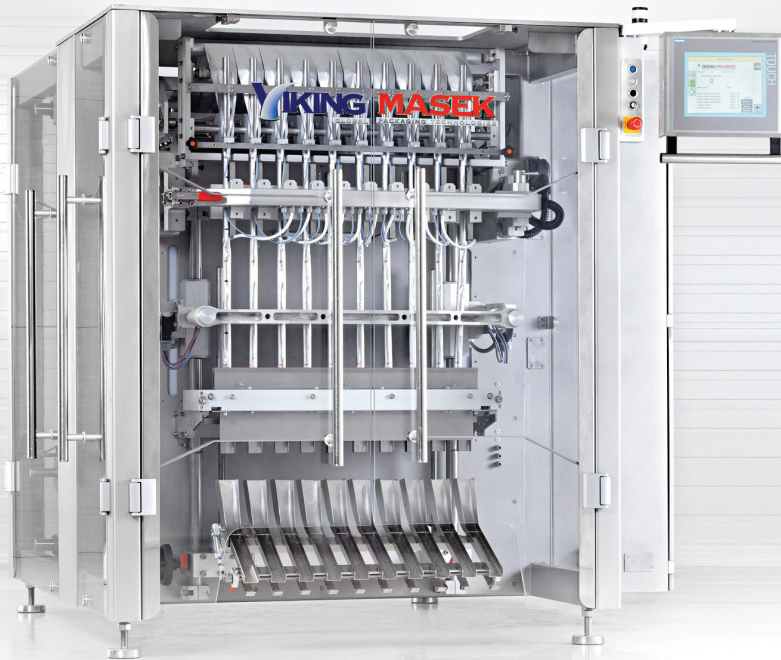

max.  
speed

80  
cpm

bag  
size

max.  
80 × 200 mm (3.15" × 7.88")  
min.  
17 × 40 mm (0.67" × 1.57")



Bag  
Types

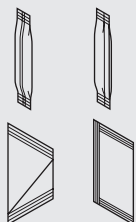

Bag  
Options

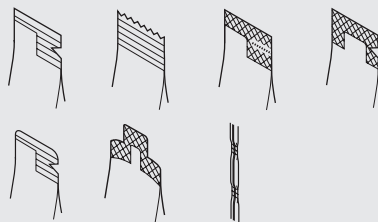

# Multilane Stickpack Machine ST800 In Detail

Looking for flexibility in your stickpack needs? Our versatile multi-lane ST800 stickpack machines can accommodate from 1 to 20 lanes to form different shapes of stickpack pouches. Designed to pack powders; dense, fine, loose and particulate materials as well as liquids and gels into stickpack bags and to accommodate different bag shapes including pour spouts, tear notches and easy-open system. We also offer fully automated cartoning solutions to suit your needs.

## features



- Powered film unwind with film tension control
- Film slitters and forming tubes – set per bag size
- Discharge chutes
- Siemens or Allen Bradley control system
- Automatic film tracking
- GMP construction
- Easy change-over™
- Quick film splice table
- Photo eye for bag length control

## options



- Straight cut
- Zigzag cut
- Round cut
- Die cut
- Easy change-over parts and stainless steel storage cart
- Easy open features like tear notch, microperforation or laser score
- Various seal patterns and shapes
- Offset back seal
- Automatic stickpack length adjustment
- Individual discharge chutes
- Empty stick detection
- Empty stick rejection
- Dust suction nozzles
- Static elimination
- Film edge trimming and suction
- Embossing in the longitudinal seal
- Stainless steel construction
- Pharma construction (IQ/OQ)
- Hot stamp, Inkjet, or thermal transfer printer
- Multi-lane volumetric filler, servo auger filler or servo liquid fillers
- Robotic pick-and-place unit and automatic cartoning solutions
- In-feed and out-feed conveyors

## Machine drawings

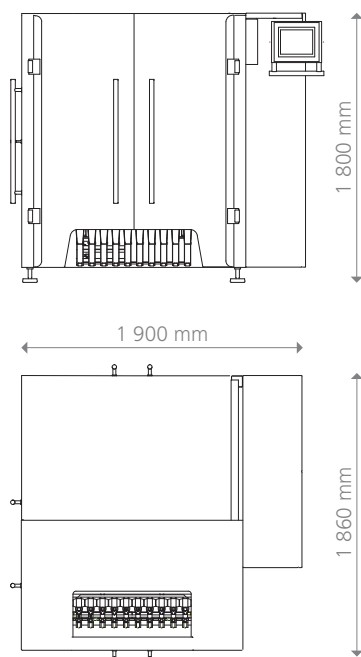

## Max. speed

80 cpm

## Weight

1 200 kg (2,650 lbs)

## Bag width

17–80 mm  
(0.67”–3.15”)

## Air pressure

6 bar  
(30 CFM at 90 PSI)

## Bag length

40–200 mm  
(1.57”–7.88”)

## Power supply

6.5 kVA



### Europe, Asia, Africa, Australia

Viking Mašek, a.s. | Průmyslová 1747 | 258 01 Vlašim | Czech Republic

Phone +420 317 850 500 | Email [info@masek.cz](mailto:info@masek.cz) | Website [www.masek.cz](http://www.masek.cz), [www.vikingmasek.cz](http://www.vikingmasek.cz)

### North and South America

Viking Masek Global Packaging Technologies, Inc. | 40 Woodland Court | Oostburg, WI 53070 | USA

Phone +1 920 564 5051 | Email [sales@vikingmasek.com](mailto:sales@vikingmasek.com) | Website [www.vikingmasek.com](http://www.vikingmasek.com)