

CAM-S



Features

- ▶ Rugged stainless steel construction
- ▶ Servo drive
- ▶ Siemens or Allen Bradley controls
- ▶ Easy change-over
- ▶ Driven carton magazine
- ▶ Excellent accessibility
- ▶ No product - no carton

Options

- ▶ Various styles of outfeed conveyors
- ▶ Damaged carton rejection
- ▶ Remote control
- ▶ Extended carton magazine
- ▶ Special electrics and voltages
- ▶ Infeed conveyors designed for product shape



Viking Masek CAM-S machines are a family of sleeve cartoning equipment. Designed to customer's requirements this machines is a great solution for packaging of ready meals, salads and other jars or cans.



Specification

MAX SPEED

50 cpm

MAX BAG SIZE

200 x 230 x 50 mm

MIN BAG SIZE

150 x 155 x 40 mm

WEIGHT

1.500 kg

POWER SUPPLY

5 kVA

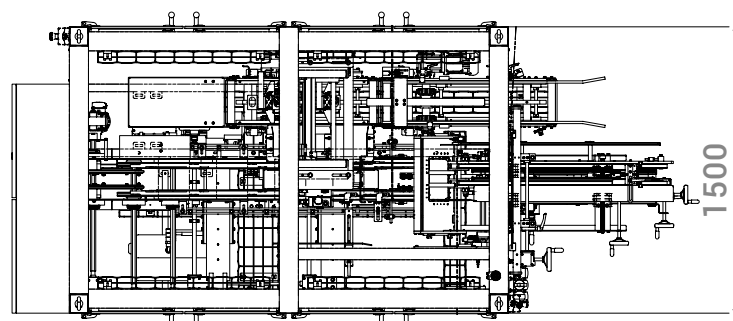
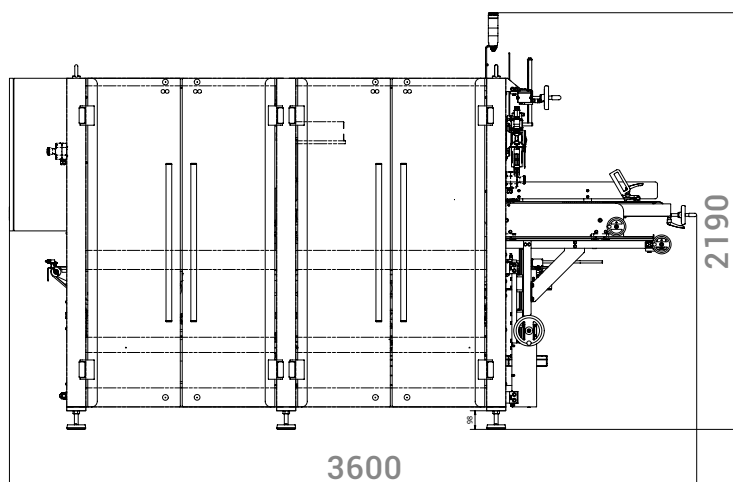

Wrap-around process

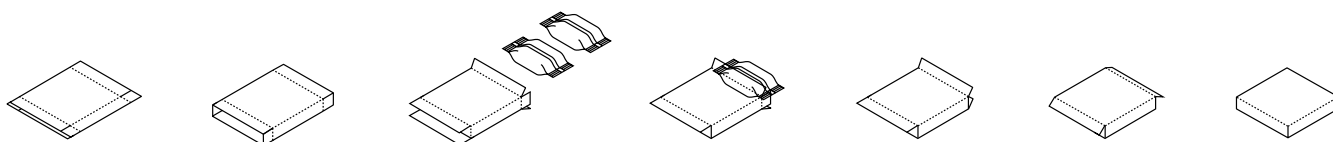

Flexible division

Viking Masek, a.s.
Průmyslová 1747
258 01 Vlašim
Czech Republic
+420 317 850 500
info@masek.cz
www.masek.cz

Cartoning division

Viking Masek, a.s.
Tovární 357
362 25 Nova Role
Czech Republic
+420 359 888 400
info@masek.cz
www.masek.cz

North American division

Viking Masek Global Packaging Technologies
40 Woodland Court
Oostburg, WI 53070
USA
+1 920 564 5051
sales@vikingmasek.com
www.vikingmasek.com

