

Viking Masek Flow Wrapper FW-9000

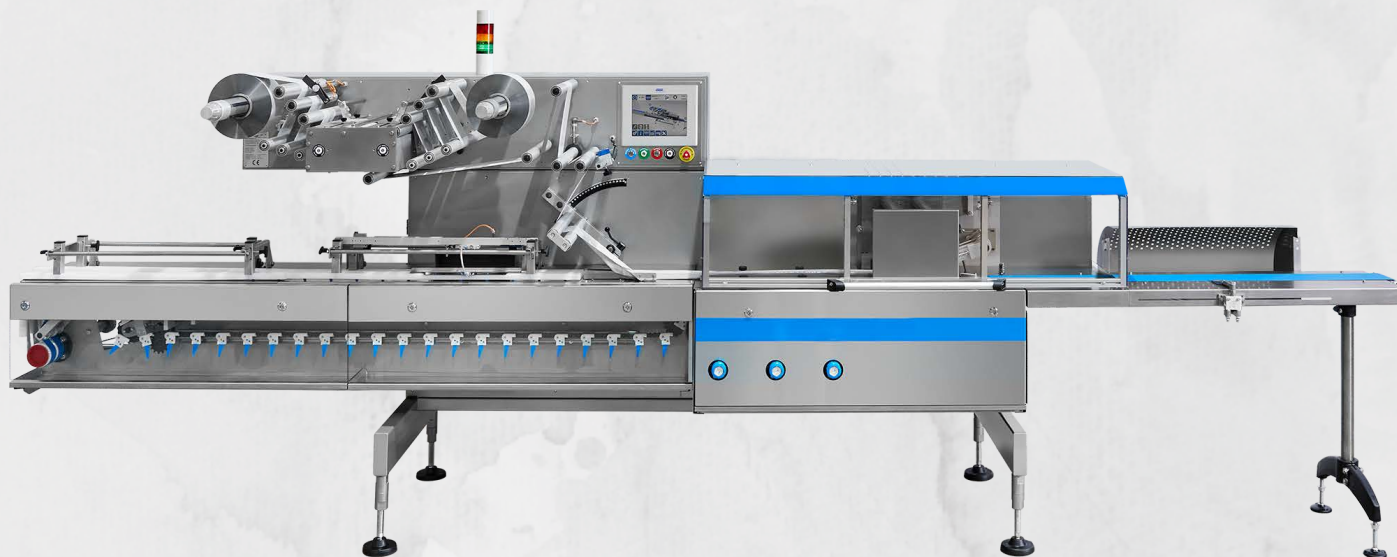

The FW-9000 (top film reel holder) is the premiere choice servo-driven machine to wrap a variety of products & for high speed production runs with fully automatic feeding and multiple format changes.

Featuring a robust machine build, cantilever design, modular construction, high flexibility & performance, Ease of operation & changeover, low maintenance cost and servo-driven controls, are the main features of this model of wrapping machine.



max.
speed

1000 bpm



bag
size

max.
170 × 450 mm (6.69" × 17.72")

min.
10 × 20 mm (0.39" × 0.79")



machine
formats

5
configurations



Flow Wrapper 9000 In Detail

The FW-9000, equipped with a top film reel holder, is the premier servo-driven machinery option for packaging a diverse range of products. It's perfect for high-speed production runs, offering fully automatic feeding and multiple format change capabilities.

This common platform has been used to develop multiple configurations that, combined with a wide range of available accessories allows the FW-90 to be integrated with many different products as well as to the most demanding requirements in a wide range of production environments. Our extensive experience also enables us to offer a wide number of accessories and feeding systems for a large variety of different products.

Max. speed
1000 bpm

Weight
1000 - 1500 kg
(2205 - 3307 lb)

Bag width
10 - 170 mm
(0.39" - 6.69")

Air pressure
6 bar
(15-18 CFM at 90 PSI)

Bag length
20 - 450 mm
(0.78" - 17.72")

Power supply
380-440 VAC / 3 Ph / 50-60 HZ

features



- Pallet conveyor
- Reel holder
- Fixed forming box
- Longitudinal sealing unit
- Longitudinal welding module
- Cutting and welding unit
- Outfeed conveyor with ejection
- Transmission cabinet
- 10.4" touch screen color HMI
- Automatic feed
- Easy changeover
- Cantilevered design
- Modular construction
- Minimal maintenance requirements
- Automatic film splice
- Robust stainless steel build

options



- Thermo configuration for heat sealable films
- Cold configuration for cold sealing films
- RT configuration for rotary type sealer/cutter
- Robotic handling for right hand execution
- Integration with feeders
- Integration with ancillary equipment

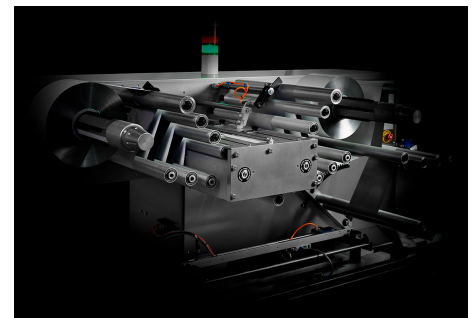
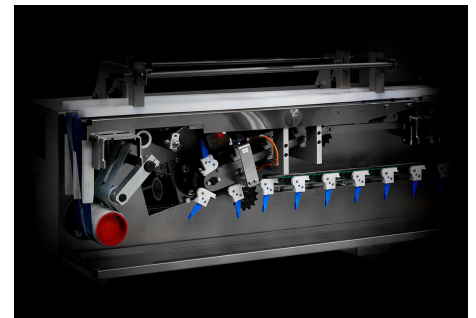

Machine drawing

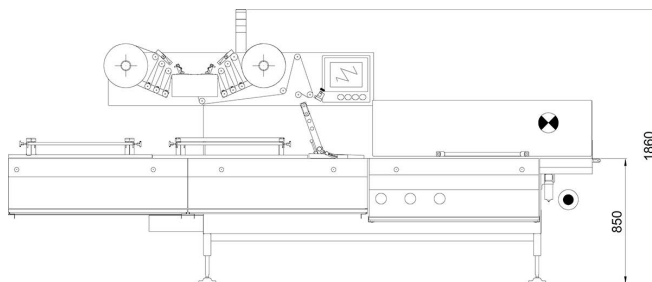

US Headquarters

Viking Masek Global Packaging Technologies, Inc. | 40 Woodland Court | Oostburg, WI 53070 | USA
Phone +1 920 564 5051 | Email sales@vikingmasek.com | Website www.vikingmasek.com