

Viking Masek Flow Wrapper Synchronpack-900



The Synchronpack-900 (top film reel holder) is the servo-driven machine to wrap regular products with semiautomatic or automatic feeding and multiple format changes.

Featuring a robust machine build, cantilever design, modular construction, high flexibility & performance, Ease of operation & changeover, low maintenance cost and servo-driven controls, are the main features of this model of wrapping machine.

- 
max. speed 500 bpm
- 
bag size max. 270 x 550 mm (10.72" x 21.65")
min. 10 x 50 mm (0.39" x 1.96")
- 
machine formats 7 configurations



Flow Wrapper 900 In Detail

This common platform has been used to develop multiple configurations that, combined with a wide range of available accessories allows the Synchropack-900 to be integrated with many different products as well as to the most demanding requirements in a wide range of production environments. Our extensive experience also enables us to offer a wide number of accessories and feeding systems for a large variety of different products.

Max. speed

500 bpm

Weight

1000 - 1500 kg
(2205 - 3307 lb)

Bag width

10 - 270 mm
(0.39" - 10.62")

Air pressure

6 bar
(15-18 CFM at 90 PSI)

Bag length

50 - 550 mm
(1.96" - 21.65")

Power supply

380-440 VAC / 3 Ph / 50-60
HZ

features



- Pusher conveyor
- Top reel holder
- Universal forming box
- Fin longitudinal sealing unit
- End cutting and welding unit
- Longitudinal welding module
- Outfeed conveyor
- Transmission cabinet
- 10.4" Touch Screen (HMI)
- Easy changeover
- Modular construction
- Minimal maintenance requirements
- Automatic film splice
- Robust stainless steel build

options



- Poly configuration for polyethylene films
- Cold configuration for cold sealing films
- Box Motion configuration for hermetic sealing
- Robotic handling for right hand execution
- Integration with feeders
- Integration with ancillary equipment

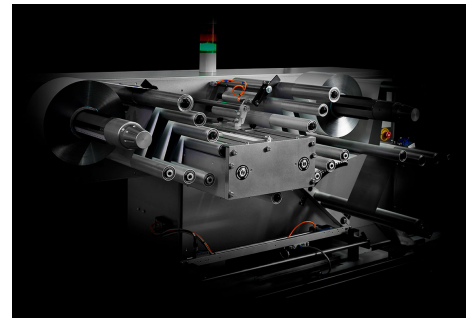
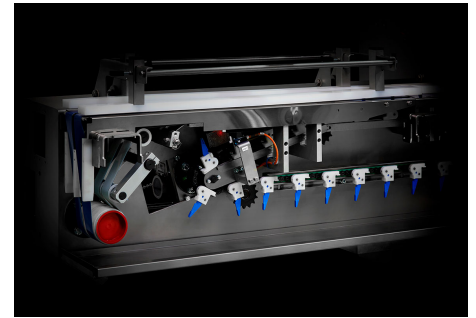

Machine drawing

